



*MODEL A-XAD-6
EXTRUDED ADJUSTABLE LOUVER
DRAINABLE BLADE*

Standard Construction:

- Frame:** 6" x .081 (152 mm x 2.1 mm) extruded aluminum (6063-T5).
- Blades:** .081 (2.1 mm) extruded aluminum (6063-T5), approximately 5" (127 mm) on centers.
- Blade Angle:** 37.5°
- Bearings:** Permanently lubricated oilite bronze, press fit into frame.
- Axles:** 3/8" (9.5 mm) square plated steel.
- Linkage:** Plated steel.
- Operator:** Wing nut slide bracket.
- Screen:** Bird screen - 3/4" x .050 (19 mm x 12.7 mm) flattened expanded aluminum in a removable frame on interior of louver.
- Finish:** Mill aluminum.
- Minimum Section Size:** 12"w x 12"h (25.4 mm x 25.4 mm)
- Maximum Section Size:** 48"w x 72"h (1219 mm x 1829 mm) with jamb seals
60"w x 96"h (1524 mm x 2438 mm) without jamb seals

Options

- Screens:** Insect screen - 18 x 16 mesh aluminum
Other - _____
- Blade Seals:** Extruded vinyl
- Jamb Seals:** Flexible Stainless steel
- Finish:** Prime Coat
Baked Enamel
Clear Anodize - 204-R1 and 215-R1
Integral Color Anodize
Kynar 500 Enamel
Other - _____
- Sill Extensions:**
 - Flange:** 1-1/2" (38 mm) (front or rear)
 - Frame:** .125 (3.2 MM) Extruded Aluminum
- Other Operator** - _____

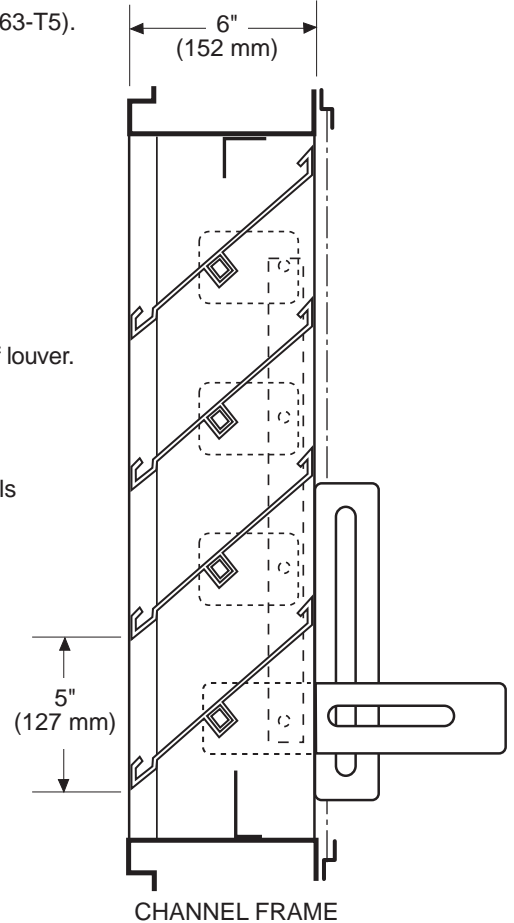

A-XAD-6 - 03-06

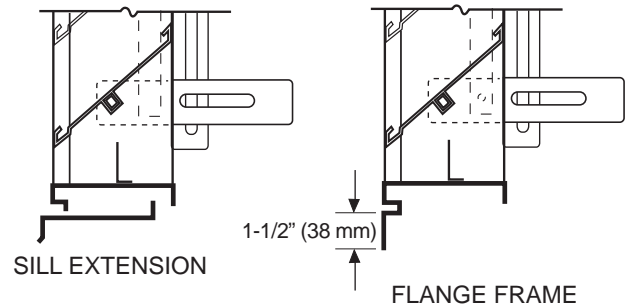
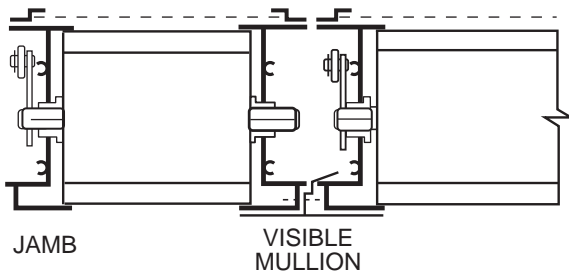

Specifications are correct at time of printing. However, as part of our 'continuous improvement program,' we reserve the right to make further improvements without notice.
© March, 2006 NCA Manufacturing

Project:
Location:
Architect:
Engineer:

Contractor:
Address:
P.O. Number:
Date:



*MODEL A-XAD-6
EXTRUDED ADJUSTABLE LOUVER
DRAINABLE BLADE*

PERFORMANCE DATA
Specifications

© March, 2006 NCA Manufacturing

Furnish and install where shown model **A-XAD-6** louver, manufactured by **NCA Manufacturing**. Louvers shall be the **Adjustable Drainable Blade** type with a frame depth of **6 inches**. Frames and blades shall be .081 inches thick 6063-T5 extruded aluminum alloy. Blades shall be located on a **37.5 degree** blade angle. Screens shall consist of 3/4" expanded aluminum, with an aluminum frame, mounted to the louver interior, and be removable for cleaning. Louvers shall be finished with Polyurethane Acrylic enamel, Kynar 500, Anodize or other finishes selected by the architect from NCA standard color charts.

A-XAD-6 FREE AREA IN SQ. FT.

		Width - Inches															
		8	12	18	24	30	36	42	48	54	60	66	72	78	84	90	96
Height - Inches	12	0.13	0.23	0.38	0.54	0.69	0.85	1.00	1.15	1.31	1.46	1.62	1.77	1.92	2.08	2.23	2.38
	18	0.25	0.45	0.74	1.04	1.34	1.63	1.93	2.23	2.52	2.82	3.12	3.41	3.71	4.01	4.30	4.60
	24	0.35	0.63	1.06	1.48	1.90	2.32	2.74	3.16	3.59	4.01	4.43	4.85	5.27	5.69	6.12	6.54
	30	0.55	0.98	1.64	2.29	2.94	3.60	4.25	4.91	5.56	6.21	6.87	7.52	8.17	8.83	9.48	10.14
	36	0.67	1.20	1.99	2.79	3.59	4.38	5.18	5.98	6.77	7.57	8.37	9.16	9.96	10.76	11.55	12.35
	42	0.77	1.39	2.31	3.23	4.15	5.07	5.99	6.92	7.84	8.76	9.68	10.60	11.52	12.45	13.37	14.29
	48	0.88	1.57	2.62	3.67	4.71	5.76	6.81	7.85	8.90	9.95	10.99	12.04	13.09	14.13	15.18	16.23
	54	0.98	1.76	2.93	4.10	5.28	6.45	7.62	8.79	9.96	11.13	12.31	13.48	14.65	15.82	16.99	18.16
	60	1.17	2.11	3.51	4.92	6.32	7.73	9.13	10.53	11.94	13.34	14.74	16.15	17.55	18.96	20.36	21.76
	66	1.29	2.33	3.87	5.42	6.97	8.51	10.06	11.61	13.15	14.70	16.25	17.79	19.34	20.89	22.43	23.98
	72	1.40	2.51	4.18	5.86	7.53	9.20	10.87	12.54	14.21	15.89	17.56	19.23	20.90	22.57	24.24	25.92
	78	1.50	2.70	4.50	6.29	8.09	9.89	11.68	13.48	15.28	17.07	18.87	20.67	22.46	24.26	26.06	27.85
	84	1.61	2.89	4.81	6.73	8.65	10.58	12.50	14.42	16.34	18.26	20.18	22.11	24.03	25.95	27.87	29.79
90	1.80	3.24	5.39	7.55	9.70	11.85	14.01	16.16	18.31	20.47	22.62	24.78	26.93	29.08	31.24	33.39	
96	1.92	3.45	5.75	8.05	10.34	12.64	14.94	17.23	19.53	21.83	24.12	26.42	28.72	31.01	33.31	35.61	

A-XAD-6 - 03-06

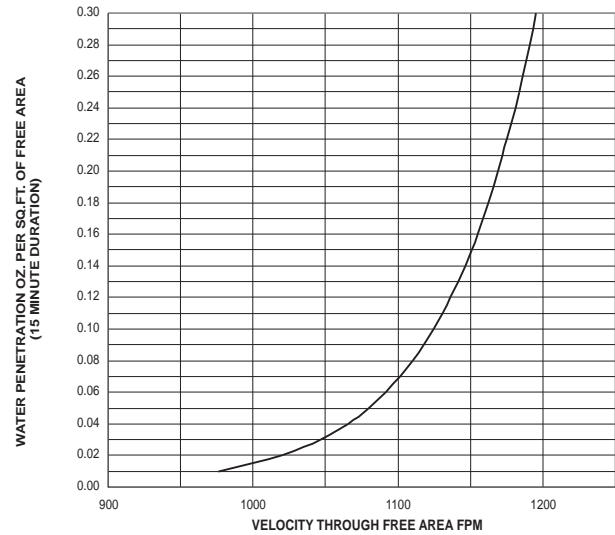
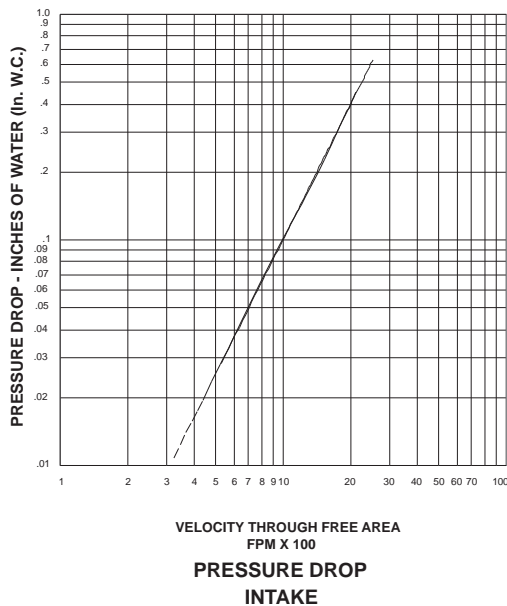

Water Penetration

Water Penetration Data applies to test unit size 48" x 48" only. Beginning of Water Penetration is 976 FPM Free Area Velocity.

Performance shown is at standard air density 0.075 lbs./ft³.

Pressure Drop Data applies to test unit size 48" x 48".

Performance data does not include the effects of bird screen.